

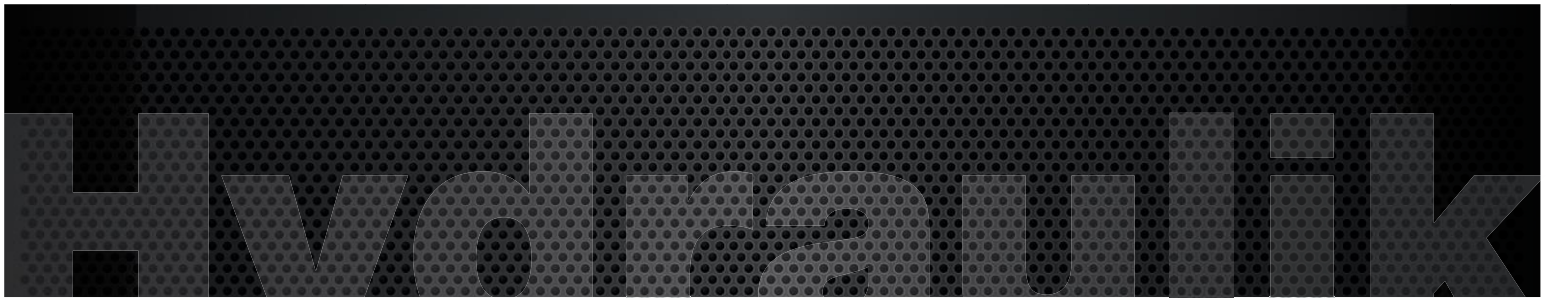

Solutions
in motion



SINGLE STAGE – **RESIDENTIAL** INSTALLATION GUIDE



Product **presentation**



2

Residential jack

Table of **contents**

Product presentation	2
Technical drawing – Head	4
Technical drawing – Bottom	5
Product characteristics	6
“1 piece” jack installation	7
“Multi-pieces” jack installation	8
“Multi-pieces” piston assembly	10
Loctite application instructions	12
Maintenance program	13
Warranty policy	14-15

Technical drawing - **Head**

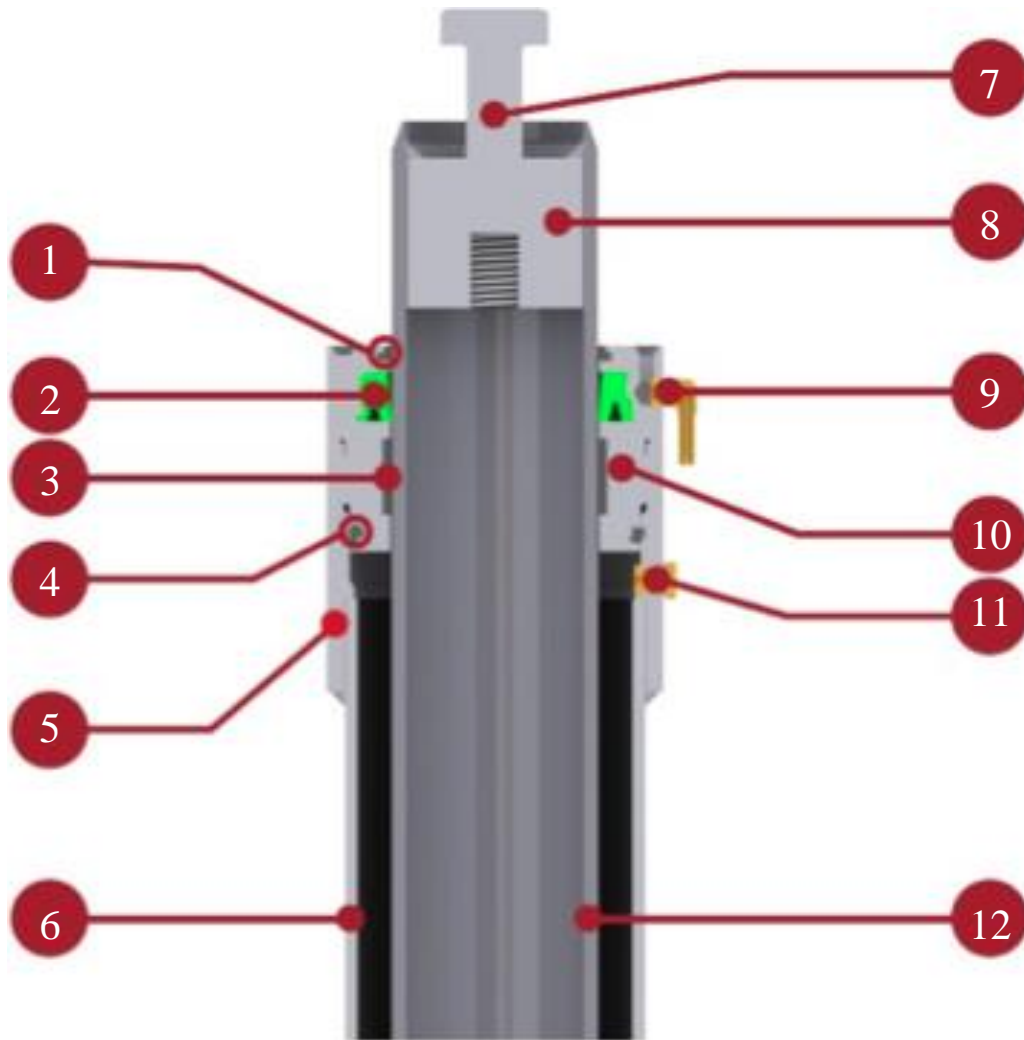

#	Components	Materials
1	Wiper	Plastic
2	Joint	Plastic
3	Wear-ring	Plastic
4	O'ring	Plastic
5	Flange	Steel
6	Casing	Steel

#	Components	Materials
7	Bolt	Steel
8	Attachment	Steel
9	Oil recuperator	Plastic
10	Head	Cast iron
11	Bleeder	Steel
12	Piston	Steel

Technical drawing – **Bottom**

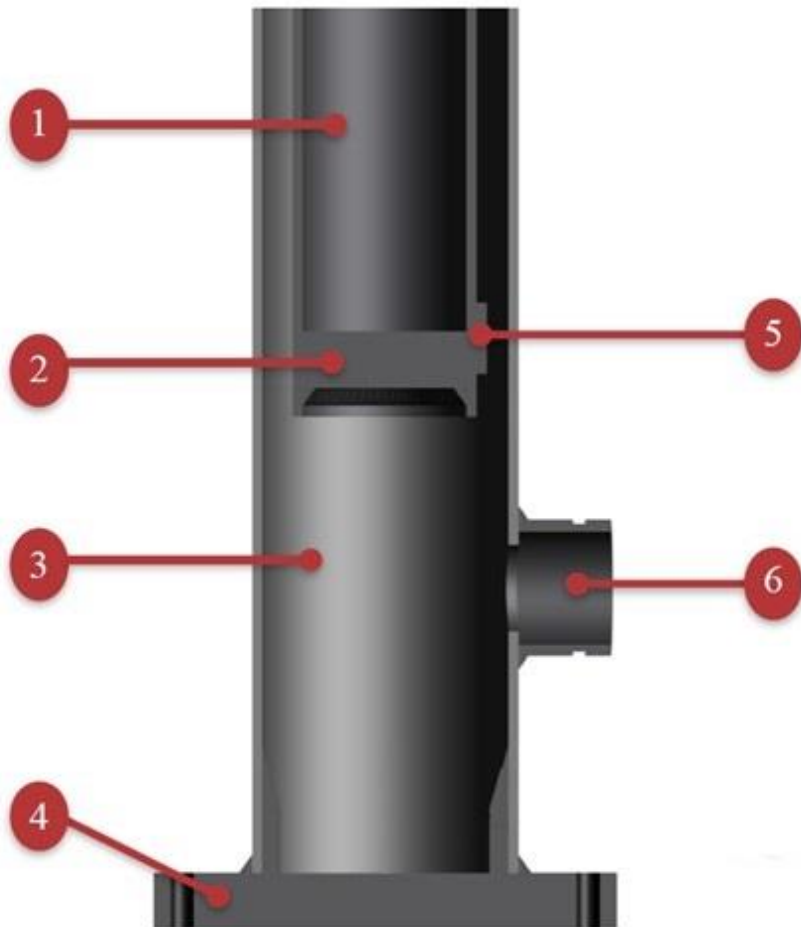

#	Components	Materials
1	Piston	Steel
2	Piston end	Steel
3	Casing	Steel
4	Casing end	Steel

#	Components	Materials
5	Stop tube	Steel
6	Oil inlet	Steel

Product **characteristics**

Available configurations

- Holeless or semi holeless
- One or two jack (twin)
- Cable/Wire

Standard dimension

Piston

From 1 1/2" to 3 1/2" (diameter)

Casing

From 2 1/2" to 4 3/4" (diameter)

Fabrication

Conception and fabrication of the products is in accordance with the CSA B44-13 and ASTM A17.1-2013 standards. Our welding procedures are certified according to the CSA W47.1 standard by the Canadian Welding Bureau (CWB).

Scope

- Dumb-waiter lifts
- Lift for disabled people
- Any other utilisation to suit your needs

Further information

Our cylinders are perfectly adapted to any type of elevator (passenger or merchandise).

This cylinder is proudly made in Quebec (Canada) or South Carolina (United States). It can be delivered to the destination of your choice, anywhere in the world.



“1 piece” jack **installation**

Hardware

For the cylinder installation

- 1x 90° elbow connector for the recuperator (1/8" NPT)
- 1x Bleeder (1/8" NPT)
- 1x Clear tubing (3/8")
- 1x Roll of Teflon tape

Tools

No special tools are required to install this type of cylinder.

Procedure

This particular model of jack requires no preparation prior to its installation on the site.

The following sequence should be performed to ensure a useful of the product that will meet your expectations.

1. Determine the position of the cylinder in the well
2. Drill the guiding pin's location for positioning
3. Inset the guide into the previously drilled hole
4. Connect the cylinder to the hydraulic unit
5. Test to verify proper functioning

Note *If the cylinder has a travel exceeding twenty (20) feet, a permanent bronze guide (not shown) is installed to keep the piston centered in the box during transport.*



“Multi-pieces” jack **installation**

Casing assembly

Hardware

- 1x 90° elbow connector (1/8” NPT)
- 1x Bleeder (1/8” NPT)
- 1x Clear tubing (3/8”)
- 1x Roll of Teflon tape

Tools

- Hoist
- Clamp piston
- 2x Strap wrench
- Hydraulic oil or anti-seize (ex. Loctite C5-A)
- Sand paper (320 or 400 grit)

Procedure

“No weld” casing joints

1. Install the bottom of the casing near the jack’s final location
2. Unpack the ends to install
3. Check O-rings’ conditions
4. Apply the anti-seize grease on the threads
5. Place the casing section to screw over the assembly

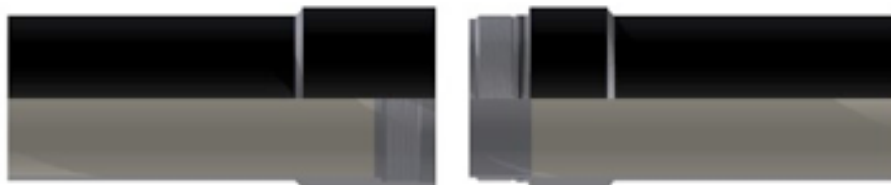

6. Make sure that the section is lined up with the bottom assembly before trying to screw the pieces together
7. Screw the piece of casing in place to align the screw indicators

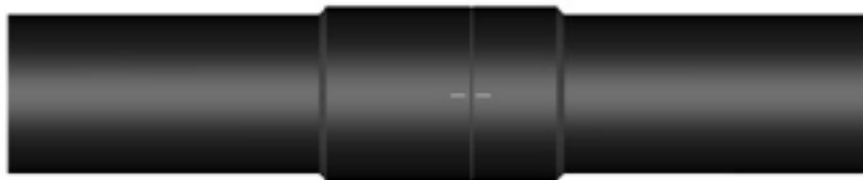

Note *The maximal distance between the two screwing indicator is 1/2”.*

8. Repeat steps 2 to 6 until the installation of the upper piece

“Multi-pieces” piston **assembly**

Hardware

- 1x Attachment bolt piston

Tools

- Hoist
- Clamp piston
- 2x Strap wrench
- Hydraulic oil or anti-seize (ex. Loctite # C5-A)
- Sand paper (320 or 400 grit)

Procedure

Before proceeding to the piston assembly in “multi-sections”, it is best to place the sections in the order taking into account the direction (up/down) of the sections. To protect the section, it is important to rest them horizontally on pieces of wood, to avoid thread damages. Ribbons of color are applied to the ends of the piston sections of easy identification.

1. Unpack only the lower part of the top section (3” long)

Note *It is very important to keep the sponge in the tube.*

2. Unpack the top of the bottom corresponding section (3” long)

Note *It is important to check carefully if the joint is not damaged (contact surfaces, threads, outside of the tubes, edges...)*

3. Clean contact surfaces and the threads on the ends of 2 sections to screw
4. Check O-rings’ conditions
5. Apply oil on the threads and contact surfaces of the two sections
6. Align the two sections



Note *The bolt on the top section can be used to handle and lift sections. If the bolt of the upper section is inconsistent with the drilling of the joint, a proper size bolt will be supplied with the bottom section's piston joint.*

7. Screw the sections until the screw marks are lined up

Note *The maximum difference between the two screw marks is $\frac{1}{4}$ ". Be careful that the weight of the top section doesn't lie on the threads of the bottom section when screwing the parts together.*

8. Use sandpaper to smooth out the joint surface

Note *To check the surface quality of the joint, just run a nail over the joint. The joint is considered to be good when you are no longer able to feel a bump at the joint location.*

9. Repeat steps 1 to 8 for each of the joints to the top of the piston assembly
10. Unwrap the protective paper being careful not to damage the piston

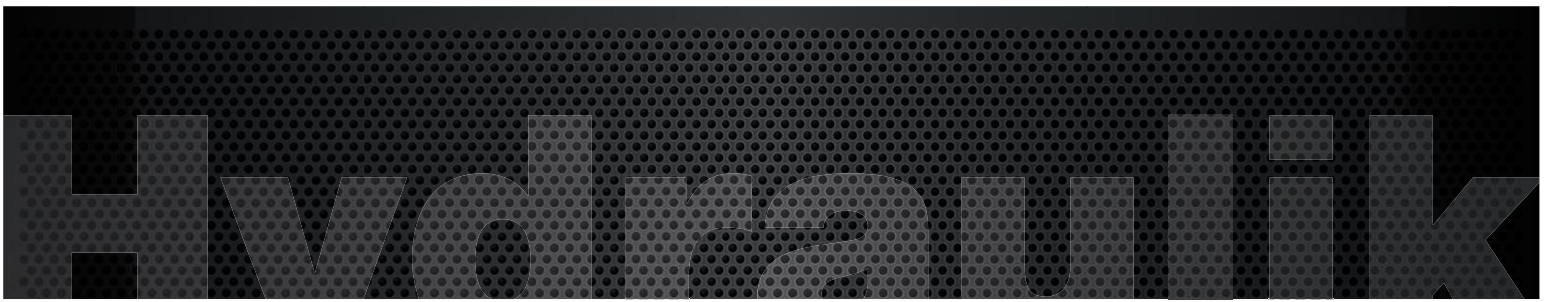

Loctite application **instructions**

- 1) Add Anti-seize on the thread of the union joint and screw the plunger piece until there is a gap of 1'' between the two plunger faces.
- 2) Clean Anti-seize from the faces and the union joint. These parts need to be clean and dry before applying the Loctite 620.
- 3) Apply the provided Loctite on piston joint, creating a 1/4'' cord. Apply once above the o'ring and once on the black wear ring guide. See image below.



- 4) Sand the joint.
- 5) Let dry for 60 minutes. Cure time before piston operation is 24 hours.
- 6) Continue screwing the pieces until the gap between faces has been eliminated and the arrow scratch marks are aligned..

Note A Loctite bottle will last for approx. 45'' worth of 1/4'' cord.

Maintenance **program**

Monthly verification

- Verify the seals
- Verify the oil level
- Verify the oil quality
- Verify if there are leaks on the line

Note *If the seals need to be replaced often, the surface of the piston should be carefully inspected as it can be damaged, wearing the seals prematurely.*

Annual verification

- Verify the line strainer
- Verify the piston surface

Seal replacement

1. Attach the cabin as high as possible, high enough to be able to remove the head and change the joints.
2. Once the car is held securely, close the main switches.
Note: take all protection you are trained to before going forward
3. Unscrew the bolt above the piston retaining the cabin.
4. Open the manual valve to relieve pressure until the cylinder fully collapses.
5. Close the ball valve on the power unit to keep the oil in the tank.
6. Disconnect the hose on the head (return to the tank).
7. Remove the head by using two chain wrenches, one on the head and one on the flange. Just turn the head counter clockwise.
8. Remove the old joint and O'ring.
9. Install the new joint and O'ring and apply oil on every surface.
10. Reinstall the head.
11. Close the manual valve.
12. Reconnect the hoses on the head.
13. Open the ball valve on the power unit and open the main switches.
14. Get the piston to lift slightly to rate a pressure inside the jack.
15. Open the bleeder until the oil drips out and then close it.
16. Attach the piston to the cabin with the bolt.
17. Test the cylinder by making it go up and down 5 times.

Note *Insure you did not damage the O'ring when you installed the head.*

Warranty policy

GUARANTEE

1. ITI HYDRAULIK warrants to the original purchaser that this Product is free from any defects in materials or workmanship and agrees to repair or replace, in its sole discretion, any Product found to be defective during the period of **one year** from the date of delivery to the customer.
2. This warranty is only given to the original purchaser and comes into force on the delivery date of the Product.
3. The delivery date is the date of assumption of responsibility of the Product, ascertained by the bill of lading of the carrier.
4. Any part of this Product deemed, after reasonable evaluation by ITI HYDRAULIK, to be defective in workmanship or materials, will be repaired or replaced, free of charge for parts and labor, by ITI HYDRAULIK.

LIMITATION OF WARRANTY

5. This quality guarantee covers any defect in the manufacture or materials of the sold Product provided that:
 - (a) the Product is used for the purpose for which it is designed, intended and recommended by ITI HYDRAULIK;
 - (b) the Product has been installed and maintained by qualified personnel; and
 - (c) the maintenance recommended by ITI HYDRAULIK has been carried out by qualified personnel.
6. This warranty does not cover claims for damages, direct or indirect, for loss of time, or caused by a Product modification, Product tampering or Product adjustment made by or for the Buyer and not previously approved by ITI HYDRAULIK.
7. This warranty does not cover Product that has been damaged through abuse, neglected, lack of maintenance or failure to maintain the Product pursuant to the instructions in the user manual provided by ITI HYDRAULIK.
8. This warranty does not cover repairs necessitated by normal wear and tear of the Product or the use of unapproved parts and accessories with the Product or that are harmful to its proper functioning, performance or durability. In addition, this warranty excludes: consumable materials – hydraulic fluids, etc.
9. This warranty does not cover damage caused during transport, installation, maintenance or return of the Product. The Buyer shall promptly notify ITI HYDRAULIK in writing sent by mail, fax or registered mail when a defect is discovered, with a detailed explanation of the alleged defects. ITI HYDRAULIK will not assume and therefore will not pay any amount related to the elements mentioned above.
10. This warranty can not be relinquished, transferred or assigned to a third party; it is granted exclusively to the original purchaser of the Product. In the event that the Product is sold, transferred or otherwise disposed of, this warranty becomes void immediately for all legal purposes.

SUITABILITY OF THE PRODUCT

11. ITI HYDRAULIK complies with the manufacturing standards applicable to the Product sold. States and localities are governed by codes and regulations pertaining to construction, installation and use standards, which may differ from one region to another. ITI HYDRAULIK cannot be held responsible for the conformity of the Product with the application of these codes, standards, regulations; the Buyer is solely and exclusively responsible for this compliance before the confirmation of the order.

STORAGE OF THE PRODUCT

12. Storage of ITI HYDRAULIK products is not recommended for a period longer than 1 month; a horizontal position of the Product for a period of time greater than one month, may cause oil leakage. Any temporary storage requires a dry place, protected from theft, moisture, extreme heat and cold. Damage and defects caused by improper storage, stacking or handling are not covered by this warranty.

RETURNS OF MERCHANDISE

13. Any request to return the Product must be authorized prior to shipment by ITI HYDRAULIK Technical Services. Following an authorization from ITI HYDRAULIK, a return number is assigned and must be indicated on the outer packaging of the Product return packaging. The same packing criteria as at the original packing receipt must be utilized. The customer is responsible for transporting the return of the Product to the specified ITI HYDRAULIK factory. A Product found to be defective after inspection by ITI HYDRAULIK may, in our sole discretion, be repaired or replaced at no charge. A credit request for any product return must be authorized by ITI HYDRAULIK and is subject to a 35% restocking fee, plus initial shipping costs.

TECHNICAL SERVICE

14. ITI HYDRAULIK provides free installation manuals on its website and technical assistance on its Products. This information is intended for people with knowledge and skills in this area who will use it at their own risk. ITI HYDRAULIK assumes no liability for damage caused by anyone using these manuals.

PRICES OF PRODUCTS

15. Product prices are subject to change without notice.

FORCE MAJEURE

16. From the date of delivery, the buyer assumes all liability and costs inherent to the Product. ITI HYDRAULIK shall not be considered in default in the performance of its obligations hereunder if such performance is delayed, withheld or prevented as a result of a fortuitous event or force majeure. Force majeure is any cause that ITI HYDRAULIK could not reasonably have foreseen and against which it could not have protected itself. Force majeure includes, but is not limited to, any fortuitous event, injury, illness, accident, death, destruction of property, use of the Product sold, natural disaster, strike, partial or complete stoppage of work, lockout, fire, riot, intervention by civil or military authorities, acquiescence with the regulations or orders of any governmental authority and warfare (declared or not).

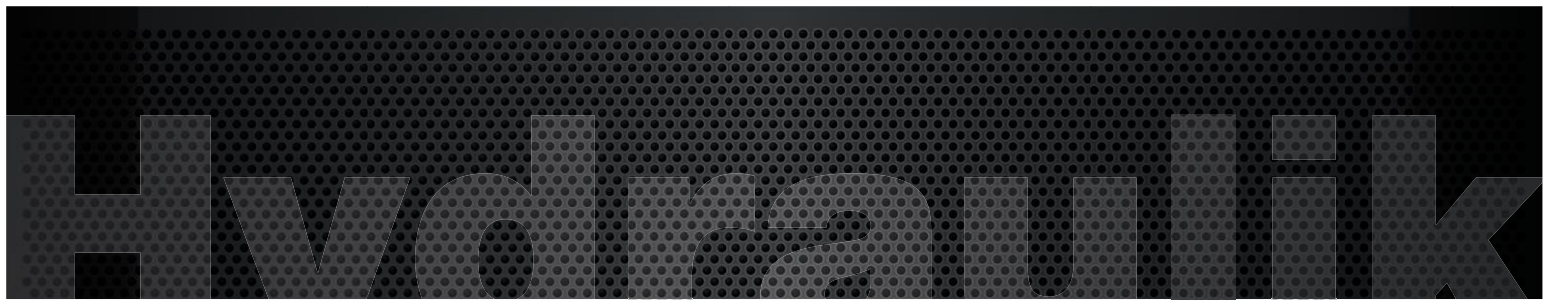

PRIORITY CLIENT

Since 20 years, the ITI engineers had access to tools and to state-of-the-art formations of the industry. It is this continues training that allows us to provide you with quality products that will meet your needs. Furthermore, we are the leaders regarding delivery deadlines.



3611 ROUTE 346, SAINTE-JULIENNE (QUÉBEC) J0K 2T0
TELEPHONE : 450-831-3229 | FAX : 450-831-2219 | TOLL FREE : 1-800-953-3229 | E-MAIL : INFO@ITIHYDRAULIK.COM

WWW.ITIHYDRAULIK.COM